

# **MRET Activated Water and its Successful Application for Prevention Treatment and Enhanced Tumor Resistance in Oncology**

**Igor Smirnov**

*Global Quantech, Inc., San Marcos, CA 92078, USA*

E-mail: [igor@gqusa.com](mailto:igor@gqusa.com)

Tel. (760)510-1333; Fax (760)510-1999

## **Abstract**

This particular article relates to a fundamental nature on how MRET Activated Water with the modified molecular structure, physical and electrodynamic characteristics may enhance specific molecular mechanisms in living cells. The research regarding the physical parameters of water confirmed that MRET treatment of distilled water led to substantial modification of basic physical-molecular properties of water. The anomalous viscosity of MRET water (subject to very low tangent pressure) and electrodynamic characteristics of MRET water (subject to applied electromagnetic field of low frequency range) confirm the high level of long-range dynamic structuring of water molecules in polarized-oriented multilayer formations in activated water produced with the help of MRET activation process. The similarity of molecular formations of cell water and MRET activated water contributes to their compatibility, easy bio-availability and assimilation of MRET activated water in biological systems. The introduction of MRET water to biological systems can contribute to the enhancement of the cellular transduction mechanism and the proper function of cells in biological systems. The significant positive effect of MRET Activated Water regarding the tumor resistance on animals was observed in all groups of mice on different fractions of MRET water in the experiments conducted on 500 mice at Kiev Institute of Experimental Pathology, Oncology and Radiobiology, Ukrainian Academy of Science. The best results were observed in the groups of mice on MRET water activated for 30 minutes (optimal regime of activation). The significant anti-tumor effect of MRET Activated Water on mice was close to the action of the chemotherapy agents and allowed to avoid the side effects that typically follow chemotherapy treatment in oncology.

**Keywords:** MRET Activated Water, Ehrlich Carcinoma, Sarcoma, Preventive Regime, Enhancement of Cellular Functions, Tumor Resistance, Index of Cytotoxic Activity, Viscosity, Electrical Conductivity, Dielectric Permittivity.

## **Objectives**

MRET Activated Water is produced with the help of patented in the USA Molecular Resonance Effect Technology (MRET). MRET water activator is the stationary source of subtle, low-frequency, resonant electromagnetic field with composite structure. The origin of the low-frequency composite electromagnetic field is the intensive electrical activity inside the nano-circles formed by linear molecular groups of MRET polymer compound (volumetric fractal geometry matrix) when polymeric

body is exposed to the external electromagnetic fields of specific frequency and wavelength [Vysotskii, Smirnov 2005].

This particular article relates to a fundamental nature on how MRET activated water with the modified molecular structure, physical and electrodynamic characteristics may enhance specific molecular mechanisms in living cells. The goal of this investigation was to study on mice the effect of MRET activated water as a potential agent for the prevention and treatment of two kinds of oncology diseases (laboratory models of Ehrlich's ascites tumor and Sarcoma ascites form). The research was conducted under supervision of Prof. V. Vysotskii (Kiev State University, Ukraine), S. Olishevsky, Ph.D., Y. Yanish, Ph.D. (Kiev Institute of Experimental Pathology, Oncology and Radiobiology, Ukrainian Academy of Science), and A. Kornilova, Ph.D. (Moscow State University, Russia) [Vysotskii 2006].

The research regarding the physical parameters of water confirmed that MRET treatment of distilled water led to substantial modification of basic physical-molecular properties of distilled water. The level of modification of properties of MRET water depends on the duration of the process of activation. The results also confirmed the ability of MRET activated water to keep its anomalous characteristics for several hours or days at room temperature and especially at low temperature (known in physics as the “long-term water memory” phenomenon [Vysotskii 2005, 2004]).

The experiment conducted on MRET activated water subject to tangent pressure revealed that at very low velocity of motion of water (tangent pressure in the range of 0.004 – 0.005 Pa, temperature 20°C) viscosity of water activated for 60 minutes decreased about 200 – 250 times compare to non-activated water from the same source. The most significant phenomenon of anomalous low viscosity of activated water, the decrease about 300 – 500 times, was observed for water activated for 30 minutes. These results confirm the hypothesis regarding the alteration of molecular structure in MRET activated water. Particularly, the anomalously low viscosity of MRET activated water in the area of very low tangent pressure confirms the polarized-oriented multilayer molecular structuring of MRET water: the high level of long-range molecular coupling (hydrogen bonding) inside the “layer” and very low level of molecular coupling between the “layers.”

The significant modification of electrodynamic characteristics of distilled water subject to applied electromagnetic field in the range of low frequencies was observed after MRET activation. The electrical conductivity of MRET activated water at 20°C in the range of frequencies of 0.1 Hz – 100 kHz decreased by 80 – 90% in 30 minutes activated water, and by 66 – 70% in 60 minutes activated water respectively compare to non-activated distilled water. The dielectric permittivity in the very low frequencies range of 0.1 – 1000 Hz decreased by 80 – 90% and in the range of frequencies of 1 – 100 kHz it decreased by 18% in 30 minutes activated water; the decrease by 70 – 85% was observed in the range of 0.1 – 1000 Hz in 60 minutes activated water compare to non-activated water from the same source. It is reasonable to admit that in the range of very low frequencies 0.1 – 1000 Hz the long-range multilayer molecular structures of MRET water (with high level of molecular coupling inside the “layers” and extremely low level of hydrogen bonding between the “layers”) create lower level of resistance of water dipoles to the alignment and, as a result, the dielectric permittivity of MRET water is substantially lower by 70 – 90% compare to non-activated water. This substantial decrease of dielectric permittivity also confirms the direct correlation between viscosity and dielectric permittivity of water in the range of low frequencies of applied EMF [Chaplin 2005].

The investigation regarding the electrodynamic characteristics of MRET water also revealed that the long-term storage of activated water (up to 5 hours at 20°C) did not substantially affect the modified electrodynamic characteristics of 30 minutes activated water (the reduction of conductivity still kept the level of 66 – 70% and dielectric permittivity kept the level of decrease by 50 – 55% in the range of 0.1 Hz – 1 kHz and by 18% in the range of 1 – 100 kHz respectively). The storage of 60 minutes activated water under the same conditions practically did not affect its electrodynamic characteristics (maximum difference is 2%). These results confirm the ability of MRET activated water to keep its anomalous properties for rather long period of time (known as “long-term water memory”

phenomenon) in case of 30 minutes activation and even higher level of “long-term water memory” phenomenon in case of 60 minutes activation.

The anomalous viscosity of MRET water (subject to very low tangent pressure) and electrodynamic characteristics of MRET water (subject to applied electromagnetic field of low frequency range) confirmed the high level of long-range dynamic structuring of water molecules in polarized-oriented multilayer formations in activated water produced with the help of MRET activation process. The fundamental biophysical theories revealed the scientific paradigm regarding polarized-oriented multilayer (PM) structuring of cell water in biological systems [Ling 2003, 2001, Drost-Hansen 1971, 1991]. According to the PM theory, the assumption of the formation of distinctive dynamic structure by the cell water results from its interaction with some intracellular proteins. More specifically, the dynamic structure of cell water results from its direct or indirect interaction with the positively-charged CO groups (P sites) and negatively-charged NH groups (N sites) on the “backbones” of a pervasive matrix of fully-extended proteins. These P and N-site-bearing proteins and the water molecules with which they interact constitute what is called a NP-NP system. Electrical polarization and directional orientation of multiple layers of water molecules may occur under the influence of one or two (juxtaposed) checkerboard(s) of alternatively positive and negative sites (Fig. 1):

**Figure 1:** The illustration of the way that individual ions and checkerboards of evenly distributed positively charged P sites alone (a) or negatively charged N sites alone (b) polarize and orient water molecules in immediate contact and further away. Emphasis was, however, on uniformly distanced bipolar surfaces containing alternatively positive (P) and negative (N) sites called an NP surface. When two juxtaposed NP surfaces face one another, the system is called an NP-NP system (c). [Ling 2003].

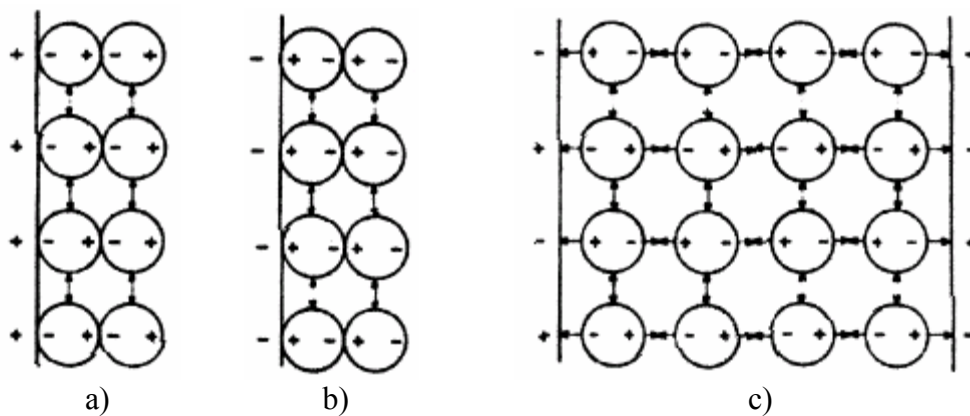

Parenthetically, water molecules may also be polarized and oriented in “layers” by a NO system or a PO system, in which electrically-neutral O sites replace properly-spaced electrically-charged P or N sites of a classic NP system respectively. The aggregate physical impacts of the NP sites on the bulk-phase water may be somewhat arbitrarily divided into three components: to enhance the average water-to-water interaction of (all) the water molecules in the system (Component 1); to reduce the translational as well as rotational motional freedom of the water molecules (Component 2); and to prolong the stay or *residence time* of each water molecule at a specific preferred location (Component 3). [Ling 2003].

The suggested model of polarized-oriented multilayer structuring of cell water due to the interaction of water dipoles with pervasive matrix of fully-extended proteins constitutes the basis for the cellular transduction mechanism. Based on this scientific approach the similarity of molecular formations of cell water and MRET activated water can contribute to their compatibility, easy bio-availability and assimilation of MRET activated water, as well as to the enhancement of cellular functions in biological systems.

The anomalous electrodynamic characteristics and viscosity of MRET Activated water provide some evidence regarding the possible effect of MRET water on the proper function of cells in biological systems. It is well known that cellular processes in biological systems are driven by the low energy of bio-chemical reactions inside and between the cells and cellular structures. Consequently, such processes create subtle low frequency electromagnetic field and low tangent pressures along water surfaces and the membranes between the cells. The anomalously low viscosity, dielectric permittivity and electrical conductivity of MRET water in the range of very low frequencies that exists in biological systems can contribute to the enhancement of the cellular transduction mechanism and result in improved intracellular/extracellular water exchange and the proper function of cells in biological systems.

The enhancement of the human body hydration was confirmed by Bioelectric Impedance Test conducted on eight human subjects at Global Quantech, Inc., USA with the help of FDA approved Bioelectric Impedance instrumentation, model Imp SFB7 and the following application of multi-frequency bioelectric impedance analysis. The experiment showed 3 times increase of the rate of intracellular/extracellular water exchange: the water exchange took 20 minutes after the ingestion of MRET activated water by human subjects compare to the 60 minutes in case of the ingestion of non-activated water by the same human subjects.

Taking into consideration the ability of MRET water to enhance morphology of human blood cells and to suppress mutated cells *in vitro* [Smirnov 2006-2, 2006-1, 2003], high germicidal activity of MRET water, the inhibition of growth of *kaluss* tissue (mutated cells of botanical origin) in MRET water (Pic 1) already confirmed by previous researches [Vysotskii 2006], the goal of this investigation was to study the effects of different fractions of MRET water on mutated cells in tumors and on the cells of immune system *in vivo*. As a result of this investigation the significant positive effect of MRET Activated water on the development of tumor resistance in animals was observed in the experiments conducted on 500 mice (22 groups with 20 mice in each group and 10 groups with 5 mice in each group).

**Pic 1:** The effect of MRET water (30 minutes and 60 minutes of activation) on the growth and development of kaluss tissue (mutated cells of botanical origin).



## Methods

In order to find out how different fractions of MRET Activated water affect the tumor resistance of organism the following experimental approaches and techniques were used in this research:

- study of possible anti-tumor efficacy of preventive administration of different fractions of activated water; for this purpose mice received activated water during 2 weeks before tumor cell transplantation and for 3 weeks after transplantation (“preventive treatment” regime);

- study of possible anti-tumor efficacy of therapeutic administration of different fractions of activated water; for this purpose mice received activated water for 3 weeks after tumor cell transplantation (“therapeutic treatment” regime);
- investigation of functional cytotoxic activity of lymphocytes containing natural killer cells (NK-cells) isolated from spleens of mice (without tumors) which received activated water; for this purpose lymphocytes were further incubated with tumor target cells.

Five different fractions of MRET activated water were prepared to elucidate effectiveness of anti-tumor effects of MRET activated water depending on time of its activation. Four water fractions were obtained after water activation for 15, 30, 45 and 60 minutes respectively. Furthermore, before the beginning of investigations a large volume of water was activated for 30 minutes and stored at 4°C during 45 days. This fraction of activated water was called “old activated water”. The inbred adult male BALB/c mice, 11 weeks old, with 23 – 24 g corporal weight were used in the study. These white mice are very susceptible to various oncology diseases. In both experiments (ascitic Ehrlich carcinoma and Sarcoma ascites form) the 5 experimental groups of mice received activated water in “preventive treatment” regime. The other 5 groups were treated with activated water in “therapeutic treatment” regime. One of the 11 groups served as a control and mice from this group received non-activated distilled water. Each group consisted of 20 mice. The cytotoxic activity of NK-cells was studied on 11 groups of mice with 5 mice in each group.

The ascitic Ehrlich carcinoma tumor cells were transplanted to all groups of mice for the first experiment. The first stage of the investigation was finished on the 8th day after tumor cell inoculation, when 10 mice from each group were sacrificed and ascitic fluids containing tumor cells were obtained from peritoneal cavities. The comparison of ascitic fluid volumes and the number of viable tumor cells from “preventive treatment”, “therapeutic treatment”, and “control” groups of mice allowed to determine the effects of applications of different fractions of activated water on growth and size of tumors in tumor-bearing mice. At the second stage of experiment the life span of tumor-bearing mice was studied.

In order to understand the possible mechanism of anti-tumor effects of MRET activated water the study of modification in cytotoxic activity of lymphocytes was conducted on another 11 groups of mice without tumors treated with different fractions of activated water. The lymphocytes contain natural killer cells (NK-cells) which have the natural function of spontaneous cytotoxicity (without prior immunization), very important for proper immune system reactions. Due to such capacity NK-cells are considered to play a critical role in immune surveillance and cancer therapy. NK-cells that infiltrate tumors may protect against tumor spread. They also produce cytokines which can contribute to the elimination of infection. Due to such capacities NK-cells and the methods of enhancement of their functional activity based on the substances of natural origin have great potentials for immune-stimulation.

The purpose of this investigation was to evaluate optimal regimes of MRET water activation and the regime of application of activated water in order to maximize the stimulation of NK-cells cytotoxic activity. In the first stage of the research mice of experimental groups received activated water during different periods of time. Mice of “preventive treatment” groups received different fractions of MRET activated water for 21 days, and mice from “therapeutic treatment” groups received it for 14 days. After the treatment with activated water mononuclear lymphocyte fractions containing NK-cells were isolated from spleens of mice of experimental groups. In the second stage cytotoxic activity of NK-cells incubated with tumor target cells obtained from peritoneal cavities of mice transplanted with ascitic Ehrlich carcinoma was studied. The incubation was conducted for 18 hours at 37°C in humidified atmosphere with 5% CO<sub>2</sub> and then the micro plates were gently centrifuged during 5 minutes.

## Results

The experimental results confirm that consumption of all types of MRET activated water leads to the significant inhibition of tumor growth observed in mice with transplanted tumors. The best results were observed in the groups of mice on MRET water activated for **30 minutes (optimal regime of activation)**. The substantial anti-tumor efficacy was confirmed by very high level of reduction of Total Number of Viable Tumor Cells which is comprised of two processes: diminishing volume of ascitic fluid in peritoneal cavity of tumor-bearing mice (**by 50%** for animals in **“preventive treatment”** group) and decrease of the number of viable tumor cells per unit of tumor tissue (**by 52%** in the same group). The resulting decrease of the Total Number of Viable Tumor Cells was **76%**. The viable tumor cells were determined by Trypan blue exclusion test: the uncolored cells were considered as viable. The test results show the dual mechanism of MRET water effect on tumors: the prevention and reduction of volume of tumors together with the inhibition of viable tumor cells. Approximately the same level of efficacy was observed in other groups (water activated for 15 and 45 minutes) with **“preventive treatment”** regime of application of activated water. The application of MRET water in **“therapeutic treatment”** regime was less effective with the similar tendency in dependency of the level of anti-tumor efficacy on the activation time. The reduction of Total Number of Viable Tumor Cells **by 55%** was observed for the optimal 30 minutes activated water. It is important to note that the long-term preservation of activated water for 45 days decreased its anti-tumor efficacy but left it on the significantly high level compare to other fractions and non-activated water. Thus, this investigation confirms that MRET activated water is efficient anti-tumor agent. The results of experimental measurements of Average Total Number of Viable Tumor Cells of ascitic *Ehrlich* carcinoma are presented on Fig 2.

**Figure 2:** The effect of preventive (1–5) and therapeutic (6–10) application of MRET activated water on average total number of viable cells  $\langle C \rangle$  in an ascetic tumor, obtained from mice inoculated intraperitoneally with tumor cells of Ehrlich carcinoma.

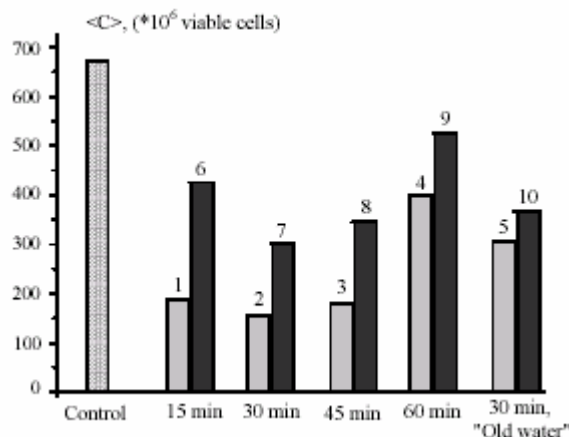

The survival of the investigated animals was daily monitored in order to study the effect of different activated water fractions on dynamic and survival indices of tumor-bearing mice. The data of the dependence of changes of life span of tumor-bearing mice for both application regimes and all types of activated water are presented on Fig 3. It shows that the consumption of MRET Activated water substantially increased survival of tumor-bearing animals. The increase of life span was observed in all groups of mice except **“therapeutic treatment”** group on water activated for 60 minutes. Water activated for **30 minutes (optimal regime of activation)** produced the most significant effect on survival of mice with transplanted tumors. The life span of mice which received optimal activated water in **“preventive treatment”** regime increased **by 61%**. Significant increase in life span (about

45%) was also observed when mice were treated with MRET activated water (activation time 15 minutes, and 45 minutes) in “preventive treatment” regime. The increase of life span **by 43%** was observed in **“therapeutic treatment”** regime for the optimal 30 minutes activated water.

**Figure 3:** The change of the percentage increase of life span of tumor-bearing mice with ascitic Ehrlich carcinoma which received different types of MRET activated water in “preventive treatment” and “therapeutic treatment” regimes. The digits under the charts correspond with the duration of water activation in minutes.

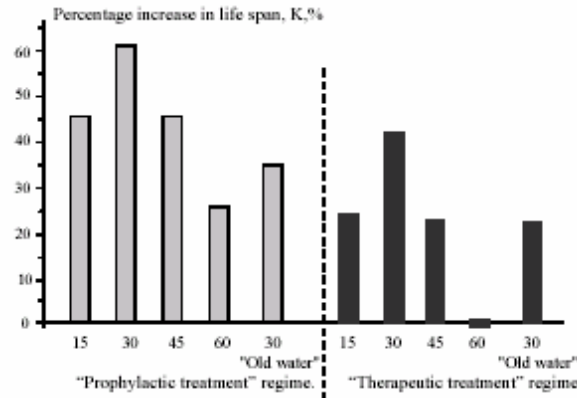

The similar investigation conducted on mice with transplanted ascitic sarcoma revealed similar tendencies in the efficacy of MRET water as anti-tumor agent with the best results on optimal 30 minutes activated water.

The effect of application of different fractions of MRET activated water on the development of cytotoxic activity of spleen mononuclear lymphocytes with NK-cells is shown on Fig 4. The increase of **cytotoxic index** in both regimes (**21 days and 14 days** of application of activated water for mice without tumors) **by 26% and 10%** respectively was observed only in the groups of mice under MRET water activated for 30 minutes. The cytotoxic index also increased in the group of mice under “old” 30 minutes activated water in “preventive” regime (21 days of MRET water application). No significant changes in cytotoxic index were observed for other water fractions.

**Figure 4:** The effect of MRET activated water on cytotoxic activity of lymphocytes containing NK-cells. Activated water was applied for mice without tumors in two regimes (for 21 and 14 days), called “preventive” (1–5) and “therapeutic” (6–10).

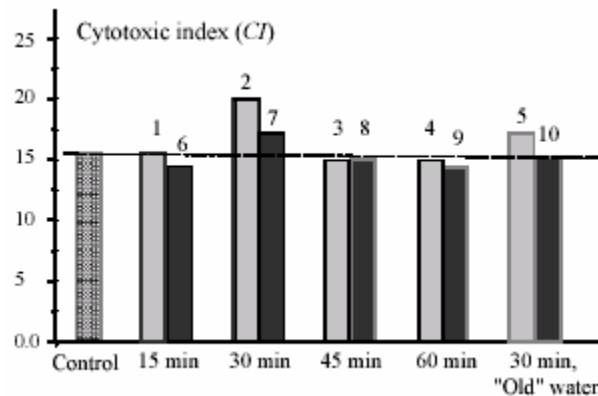

The comparative picture of tumor-bearing mice on Non-activated water and on MRET activated water (optimal activation time 30 minutes) is presented on Pic 2.

**Pic 2:** The appearance of mice from “control” (A) and “preventive treatment” groups (optimal activation time 30 minutes) (B) on the 18th day after ascitic Ehrlich carcinoma cell inoculation.



## Conclusions

The results of investigation of the application of water activated by non-ionizing Molecular Resonance Effect Technology (MRET) process for prevention treatment and enhancement of tumor resistance of animal organisms to two types of oncology diseases *in vivo* on 500 mice are presented. The research conducted on physical parameters of water confirmed that MRET activation process contributed to substantial modification of the basic physical-molecular properties of distilled water (substantial reduction of viscosity as a function of applied tangent pressure, as well as substantial decrease of electrical conductivity and dielectric permittivity as functions of the frequencies of applied electromagnetic field). The significant positive effect of MRET activated water on tumor resistance of biological organisms was observed in the process of this investigation in all groups of mice on different fractions of activated water. The best results were observed in the groups of mice on MRET water activated for 30 minutes (optimal regime of activation). The results were better in “preventive treatment” regime compare to “therapeutic treatment” regime. Additionally, this investigation confirmed that the long-term preservation of activated water at low temperature (around 0°C) for 45 days decreased its anti-tumor efficacy but left it on the significantly high level compare to other fractions. The discussion and detailed description of the mechanism of “long-term memory effect” of MRET activated water was earlier presented and published in [Vysotskii, Smirnov 2005]. The test results show the dual mechanism of MRET water effect on tumors: the prevention and reduction of volume of tumors together with the inhibition of viable tumor cells. The significant anti-tumor effect of MRET activated distilled water on mice was close to the action of the chemotherapy agents and allowed to avoid the side effects that typically follow chemotherapy treatment in oncology.

In the process of investigation of cytotoxic activity of NK-cells the significant increase of lymphocyte cytotoxicity levels was observed when donor mice were treated with MRET water activated for 30 minutes. The results also showed that the extension of the application of MRET water from 14 days to 21 days significantly increased the value of cytotoxicity index. It is possible to admit that the extension of time of application of MRET water will lead to higher levels of enhancement in NK-cells activity. Thus, the application of MRET activated water can be quite promising approach for non-drug stimulation of NK-cells immunization vaccines.

**References**

- [1] Chaplin, M. (2005) *“Water Dielectric and Microwave Radiation”* London South Bank University, <http://www.lsbu.ac.uk/water/microwave.html>
- [2] Drost-Hansen, W. (1971) In *“Chemistry of the Cell Surface”* Part B. (H.D. Brown, ed.) Academic Press, New York, p.1
- [3] Drost-Hansen, W. and Singleton, J.L. (1991) *“Our Aqueous Heritage: Evidence for Vicinal Water in Cells”* in *“Fundamentals of Medical Cell Biology”* (E.E. Bittar, ed.) Vol.3A, Chapter 5, JAJ Press, Inc.
- [4] Ling, G.N. (2003) *“A New Theoretical Foundation for the Polarized-Oriented Multilayer Theory of Cell Water and for Inanimate Systems Demonstrating Long-range Dynamic Structuring of Water Molecules”* *Physiol. Chem. Phys. & Med. NMR* 35: 91-130, USA
- [5] Ling, G.N. (2001) *“Life at the Cell and Below-Cell Level: The Hidden History of a Fundamental Revolution in Biology”* Pacific Press, New York
- [6] Smirnov, I.V. (2006-2) *“The Physiological Effect of MRET Activated Water on Patients Suffering from AIDS”* *Explore*, Vol.15, No.2: 37-40, USA
- [7] Smirnov, I.V. and Peerayot, T. (2006-1) *“The Physiological Effect of MRET Activated Water”* *Explore*, Vol.15, No.1: 38-44, USA
- [8] Smirnov, I.V. (2003) *“Mechanism of Activated Water’s Biological Effect on Viruses”* *Explore*, Vol.12, No.4: 34-36, USA
- [9] Vysotskii, V.I. (2006) *“Investigation of Physical Properties of MRET Activated Water and its Successful Application for Prophylaxis and Treatment of Oncology”* Program and Abstract Book, International Congress on Medical Physics and Biomedical Engineering, August 27 – September 1 of 2006, Seoul, Korea
- [10] Vysotskii, V.I., Smirnov, I.V. and Kornilova, A.A. (2005) *“Introduction to the Biophysics of Activated Water,”* Universal Publishers, USA
- [11] Vysotskii, V.I., Kornilova, A.A. (2004) *“The Physical Basis of Long-term Water Memory Effect,”* *Moscow University Physics Bulletin*, Vol.59, No.3: 58-62, Russia